

Multiport Electronic Fuel Injection

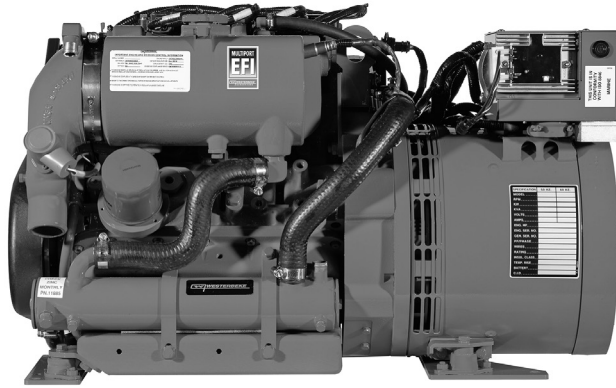

9.5/7.6 MCGB Marine Gasoline Generator
(Shown with optional 90° "REARX" exhaust)

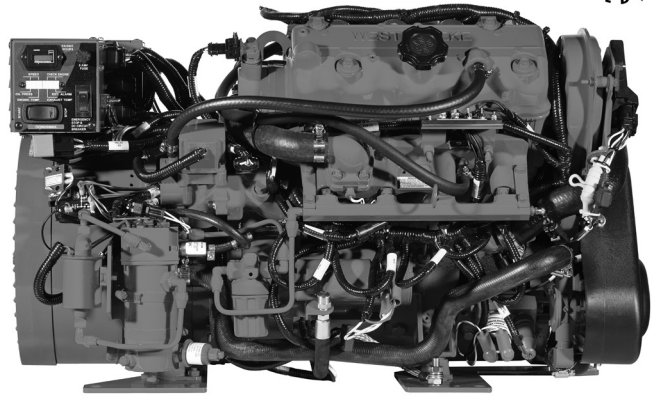

9.5/7.6 MCGB Marine Gasoline Generator
(Shown with optional 90° "REARX" exhaust)

Low-Profile, Low-Speed

The 9.5 MCGB is one of the most compact, low-speed gasoline generators on the market. Westerbeke's unique marine design allows for a high performance generator that is comparable in size to high speed designs. The lower operating speed of the 9.5 MCGB combined with a heavy duty industrial base engine contribute to a longer lasting, more reliable product.

Multiport EFI and Returnless Fuel System

The 9.5 MCGB features sequential multiport electronic fuel injection (MPI). MPI provides optimum fuel efficiency, easy starting, improved reliability and reduced emissions. In conjunction with MPI, electronic speed control maintains the engine at a constant speed (precise frequency regulation) and virtually eliminates "bogging down" when load is applied. A water cooled returnless fuel system aids in the prevention of vapor lock for improved performance in high ambient temperatures. MPI also features advanced diagnostic capabilities.

Smooth and Quiet Operation

Featuring a 4-cylinder, industrial base engine operating at an electronically controlled 1800 rpm, the 9.5 MCGB is extremely smooth and quiet running.

Five Year Limited Warranty

The 9.5 MCGB is backed by Westerbeke's 5-year limited warranty.

Standard Features

- Simple, "one touch" start/stop control panel with running hour meter and warning annunciation light strip
- Multiport EFI
- Water-cooled returnless fuel system
- Electronic governing
- Safety warnings and shut-downs: overspeed, underspeed, low oil pressure, high exhaust and coolant temperature and more
- Fresh water cooling and coolant recovery tank
- Field convertible to 50 or 60Hz
- A.C. circuit breaker
- 10 amp battery charger
- Water injected exhaust elbow
- Belt-driven raw water pump
- Vibration isolators
- Remote lube oil filter
- Lube oil drain hose
- Belt guard
- Operators' manual and parts list
- Meets applicable U.S.C.G. regulations
- Meets CARB & U.S. EPA regulations
- CE certified

Optional Venclosure (Not sold separately)



Dimensions: 34.0 x 22.6 x 19.5 inches
(LxWxH) 863 x 573 x 494 mm
Weight: 30 lbs. (14kg)

Generator Design

DESIGN: Brushless, four pole, revolving field.
VOLTAGE REGULATION: Standard +/- 5% no load to full load.
FREQUENCY REGULATION: .5 Hz (1%) no load to full load.
INSULATION: Class "H" as defined by NEMA MG1-1.66.

TEMPERATURE RISE: Within NEMA MG1-22.40 operating at full load.
COOLING: Cast centrifugal blower, direct connected.
ELECTROMAGNETIC INTERFERENCE LEVEL: Exceeds requirements for most marine radio-telephones and standard TV's.

Model	Electrical Characteristics					Ratings		Engine	
	Volts	Amps	Hertz	Phase	Wire	Power Factor	KW	RPM	Start
9.5 MCGB-614	120/240	79.1/39.5	60	1	4	1.0	9.5	1800	Remote
7.6 MCGB-514	230	33.0	50	1	4	1.0	7.6	1500	Remote

Specifications

Number of cylinders	4 Cylinder, vertical in-line	
Type	4 cycle	
Displacement	64.1 cu. in. (1.051 liters)	
Bore and stroke	2.58" x 3.07" (65.5mm x 78.0mm)	
Compression ratio	9.0:1	
Rated RPM @ 60/50Hz	1800/1500	
HP @ 1800/1500 rpm	16.8/13.4	
Maximum angle of operation	Not to exceed 25° in all directions	
Exhaust elbow conn.	2.0" OD (50.8mm)	
Raw water conn.	.75" OD (19.1mm)	
Dry weight	445 lbs (201.9 kg)	
Combustion system	Semi-spherical type	
Aspiration	Naturally aspirated	
Lubrication system	Forced pump	
Cooling system	4.75 quarts (4.5 liters)	
Full consumption (approx.)	1800 rpm	1500 rpm
100% load GPH (LPH)	1.24 (4.68)	1.00 (3.76)
75% load GPH (LPH)	1.02 (3.85)	0.84 (3.18)
50% load GPH (LPH)	0.79 (3.00)	0.66 (2.48)
25% load GPH (LPH)	0.59 (2.25)	0.48 (1.81)
Governor	Electronic	
Lube oil filter	Full flow, spin on element	
Lubricant capacity	4.1 quarts (3.9 liters)	

Fuel transfer pump	Electric type
Fuel supply	.25" ID (6.35mm)
Starting motor	12 volt, 1.4kW
Battery charging	12 amps, integral electric type
Cranking amps	120 amps @ 70 degrees F
Electrical system	12 volts DC, negative ground

Construction-Engine Components

Cylinder head	Aluminum
Cylinder block	Cast iron
Crankshaft	Forged crankshaft, four main bearings
Valves	Overhead, rotating type
Fuel system	Multiport EFI
Cooling system	Fresh water-cooled with heat exchanger
Exhaust manifold	Cast aluminum, fresh water-cooled

Optional Equipment

- Remote start/stop panel and extension harness
- "A" on-board spare parts kit
- "B" extended cruising spare parts kit
- Hydro-hush muffler and fittings
- Anti-siphon valve with 3/4 inch stainless loop
- Ship-shore switch; Auxiliary DC power adapter
- 90° water injected exhaust elbow
- Ventilated enclosure (not sold separately)

Basic Dimensions

Inches (millimeters)

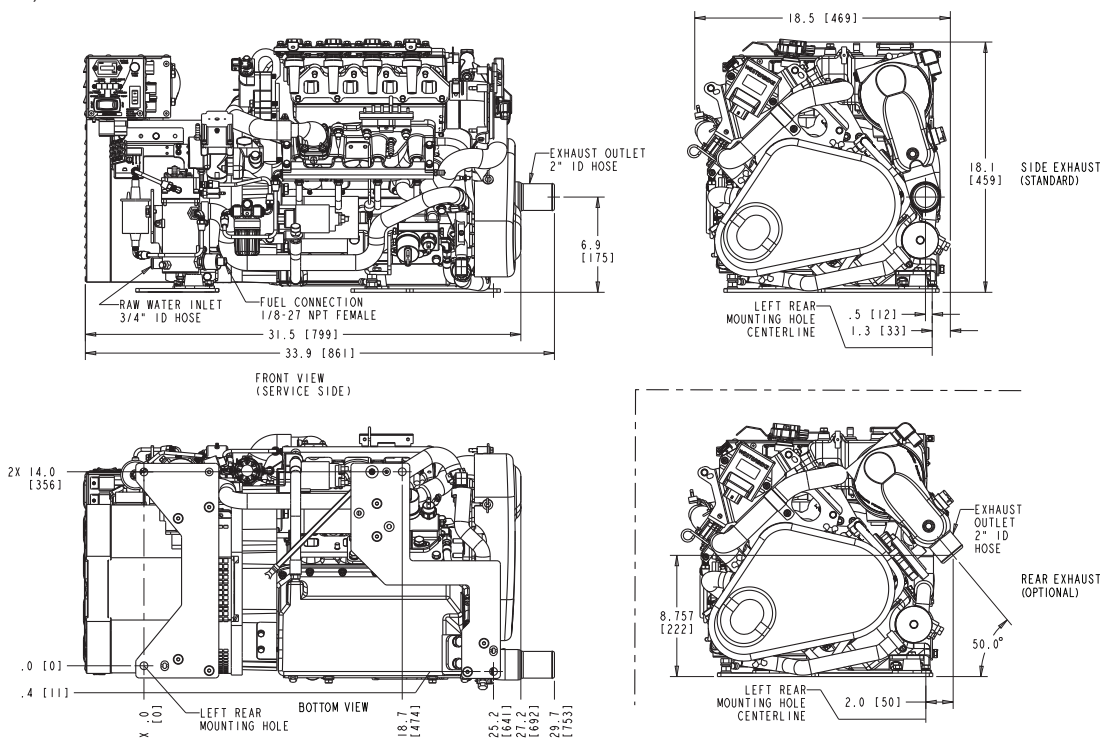

Note: Outer envelope and hose location dimensions ± .375 (9.6)

Drawings are for reference only and should not be used for installation. Detailed installation drawings are available upon request.